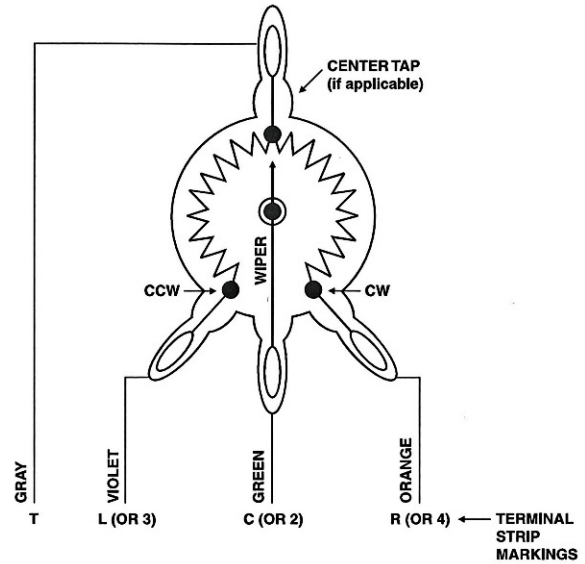
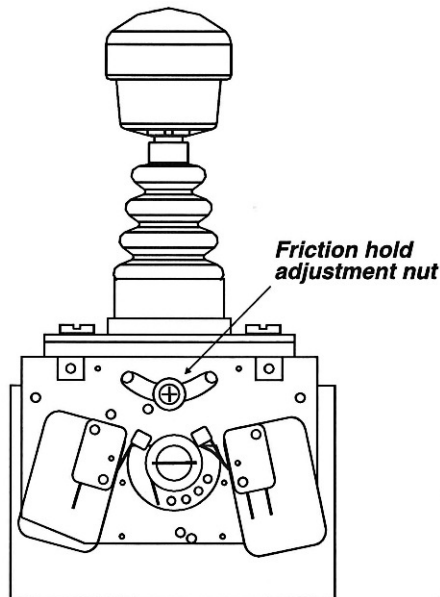

**Figure 1** Type V3 S.P.D.T. Switch



**Figure 2** Typical Potentiometer Wiring (Pot Viewed from Shaft Side)



**Figure 3** Friction Hold Adjustment

If a controller is provided with friction hold handle operation, the force required to move the controller handle can be adjusted by turning the friction hold adjustment nut (see Figure 3) clockwise to increase the friction, or counter-clockwise to decrease the friction.

**Terminal Marking for Handle-Operated Auxiliary Services:**

All switches on a controller are consecutively numbered. If a controller is provided with a handle-operated auxiliary switch which is wired to a terminal strip, the terminals will be marked as follows:

1. Normally Closed Contact= Highest Consecutive Number
2. Normally Open Contact= 2nd Highest Consecutive Number
3. Common= 3rd Highest Consecutive Number. **Example: 5=C, 6=NO, 7=NC**

**Notes:**

1. Consult applicable information bulletin for UFO electronic wiring and adjustment instructions.
2. **DO NOT** use acidic cure silicone to seal enclosures. If sealing is required, use GE Silicone II or equivalent.
3. **When ordering spare parts, please provide the controller part number for which they are being ordered.**
4. The information contained in this bulletin is for reference only and is subject to change without notice.

# Panel Mounting Dimensions

## Single-Axis Controllers

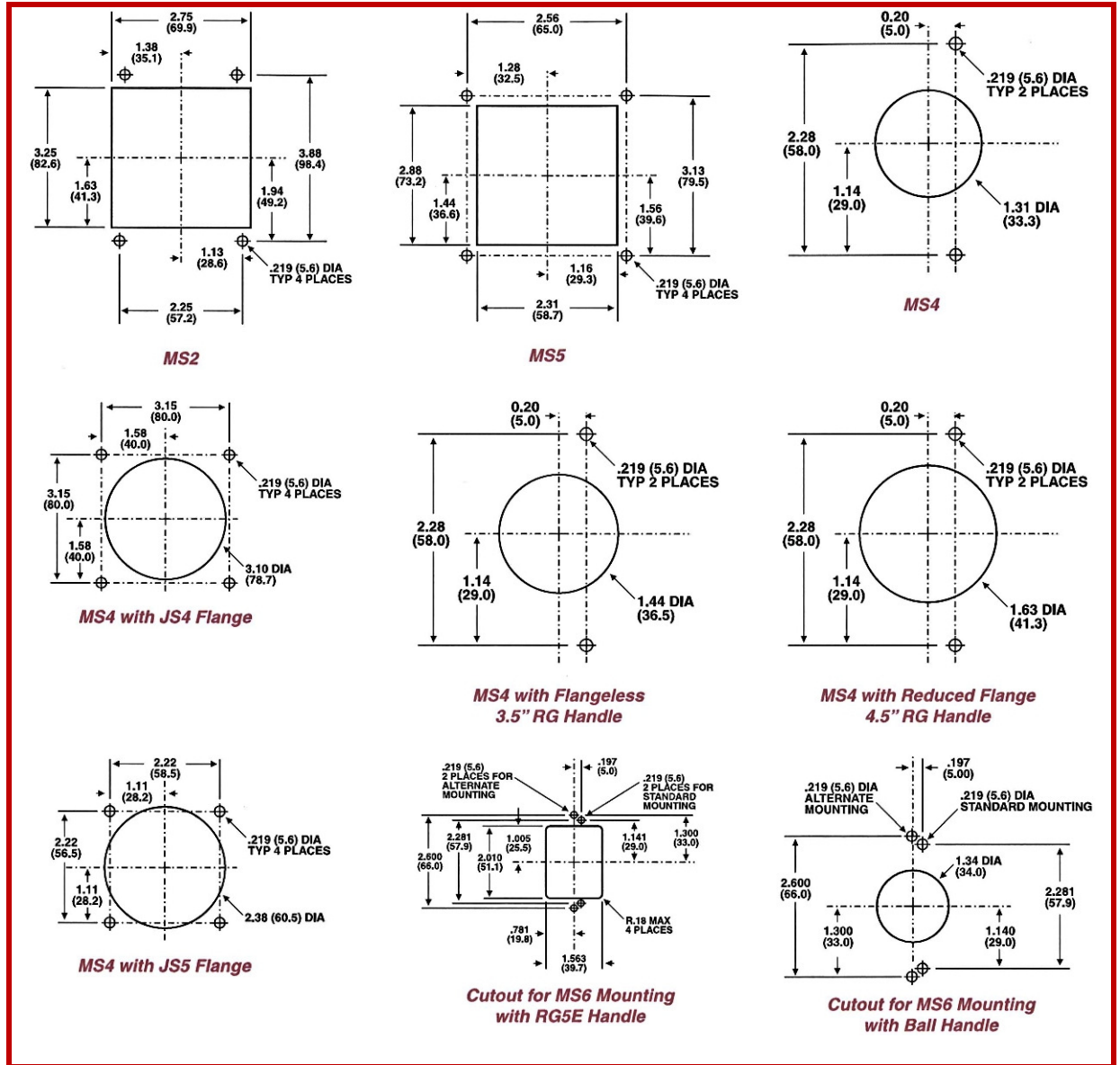

**WARNING:** It is the purchaser's responsibility to determine the suitability of any OEM Controls product for an intended application, and to ensure that it is installed and guarded in accordance with all federal, state, local and private safety and health regulations, codes and standards.

Due to the unlimited variety of machines, vehicles and equipment on which our controls are used, and the numerous standards which are frequently the subject of varying interpretation, it is impossible for OEM Controls personnel to provide expert advice regarding the suitability of a given controller for a specific application. The flexibility of our products allows us to offer thousands of custom configurations. We can advise you of the various features that are available and you can examine models to see what meets your needs. We believe our customers' engineering departments should be the qualified experts in their own product field. If the product will be used in a safety critical application, the customer must undertake appropriate testing and evaluation to prevent injury to the ultimate user.

Should you have any questions or if any of the above warning is unclear, please contact OEM Controls at 10 Controls Drive, Shelton, CT 06484, FAX: 203.929.3867, TEL: 203.929.8431.